

CANNONPUMP

Electric barrel pump

User Operating and Maintenance Manual

Original text translation

Warranty Information

CONTENT

1. INTRODUCTION
2. GENERAL DESCRIPTION
3. IDENTIFICATION OF THE MACHINE
4. TECHNICAL FEATURES
5. MACHINE COMPONENTS
6. UNPACKING AND INSTALLATION
7. INSTRUCTIONS FOR USE
8. PROBLEMS AND SOLUTIONS
9. MAINTENANCE PROCEDURES
10. DISPOSAL
11. ORDER INFORMATION
12. DIMENSIONS
13. HANDLING AND TRANSPORT
14. PRECAUTIONS FOR USE
15. OPERATIONAL HAZARDS
16. WARRANTY
17. DECLARATION OF COMPLIANCE
18. DISTRIBUTORS



1. INTRODUCTION

This is the operating and user manual for the Dropsa CannonPump.

It is possible to obtain the latest documentation by visiting our website, www.dropsa.com

This manual contains important operating and safety information for users of this product. It is essential that you carefully read this manual and conserve a copy with the product so that other users may consult it at any time.

2. GENERAL DESCRIPTION

CannonPump is an electrically driven piston barrel pump.

It is ideally suited for operation in environments where there is no compressed air available and therefore traditional pneumatic barrel pumps cannot be used.

Another key characteristic of the piston pumping mechanism design allows to it so handle hard greases without the need to pre-prime the pump with oil.

The pump also has a return line connection that allows grease pressure to be vented directly to the barrel and this means that it can be used in dual line systems without any additional modification to add a return line on the follower plate.

Dual Line Systems

Lubrication systems engineered with the Dual Line system are generally used on large scale machinery and in harsh operating conditions to lubricate multiple points on large machines. The system can grow to a very complex one with a length that often can exceed 60 meters. The large section of pump packages together with many custom design options allows any lubrication system to be developed reliably and cost-effectively.

DropsA skilled engineers are available to design large scale project and provide installation, commissioning, support and training anywhere in the world.

These pumps are supplied without accessories. It is the responsibility of the installer to ensure that the pump is suitable protected with any necessary electrical or mechanical accessory (e.g. Fuses, emergency stop switches etc).

- **The follower plate:** It is necessary to use a follower plate to correctly pump heavy grease (e.g. NLGI 2)). The plate is manufactured in 10mm/0.39" thick steel and has a lip seal around the edge and an O Seal along the central shaft to avoid grease leak-through. The follower plate:
 - Compresses grease thereby avoiding air pockets;
 - Allows effective emptying of the barrel by wiping grease from the side of the barrel that would otherwise go to waste.
- **The Barrel Cover** reduces the possible contamination of the grease in the barrel. It is supplied with retaining screws and also has the purpose of holding the pump in a correct vertical configuration.

3. IDENTIFICATION OF THE MACHINE

On the pump cover there is a product identification label that indicates the part number and characteristic of the pump, including motor voltage. Always ensure you have the correct product for your application.

4. TECHNICAL FEATURES

4.1 ENVIRONMENTAL CONDITIONS

Working temperature	<i>grease NLGI 0</i>	-10 °C ☒ +60 °C (-14 °F ☒ +140 °F)
	<i>grease NLGI 1</i>	+5 °C ☒ +60 °C (+41 °F ☒ +140 °F)
	<i>grease NLGI 2</i>	

4.2 FEATURES

N.B. The following benefits are related to the use of temperature + 20 ° C (+ 68 ° F)

GENERAL FEATURES	
Supply voltage	230V/400Vac - 3Ph - 50Hz – 0.55 kW 240/415Vac – 3Ph – 50Hz – 0.55 kW 280/480Vac - 3Ph - 60Hz – 0.65 kW 110Vac -1Ph - 60Hz – 0.9 kW 230 -1Ph - 50Hz – 0.55 kW 24Vcc – 0.55 kW
Pump type	Piston mechanism
Outlet connection	G 3/8"
Maximum pressure	250 bar (three phases motor) – 200 (mono phase motor)
Drum capacity	20 kg/25Kg - 50Kg – 180 Kg/200 Kg
Lubricant	Grease NLGI 2 max
Flow	125 cm ³ /min
Degree of protection	IP55
Gear reducer	Screw and helical wheel R=50/1
Drum Fixture	Includes radially located retaining screws
Pressure By-pass	Integrated adjustable 80÷250 bar
Minimum level	Optional
Return Line for Dual Line systems Port	1/4" BSP

5. MACHINE COMPONENTS

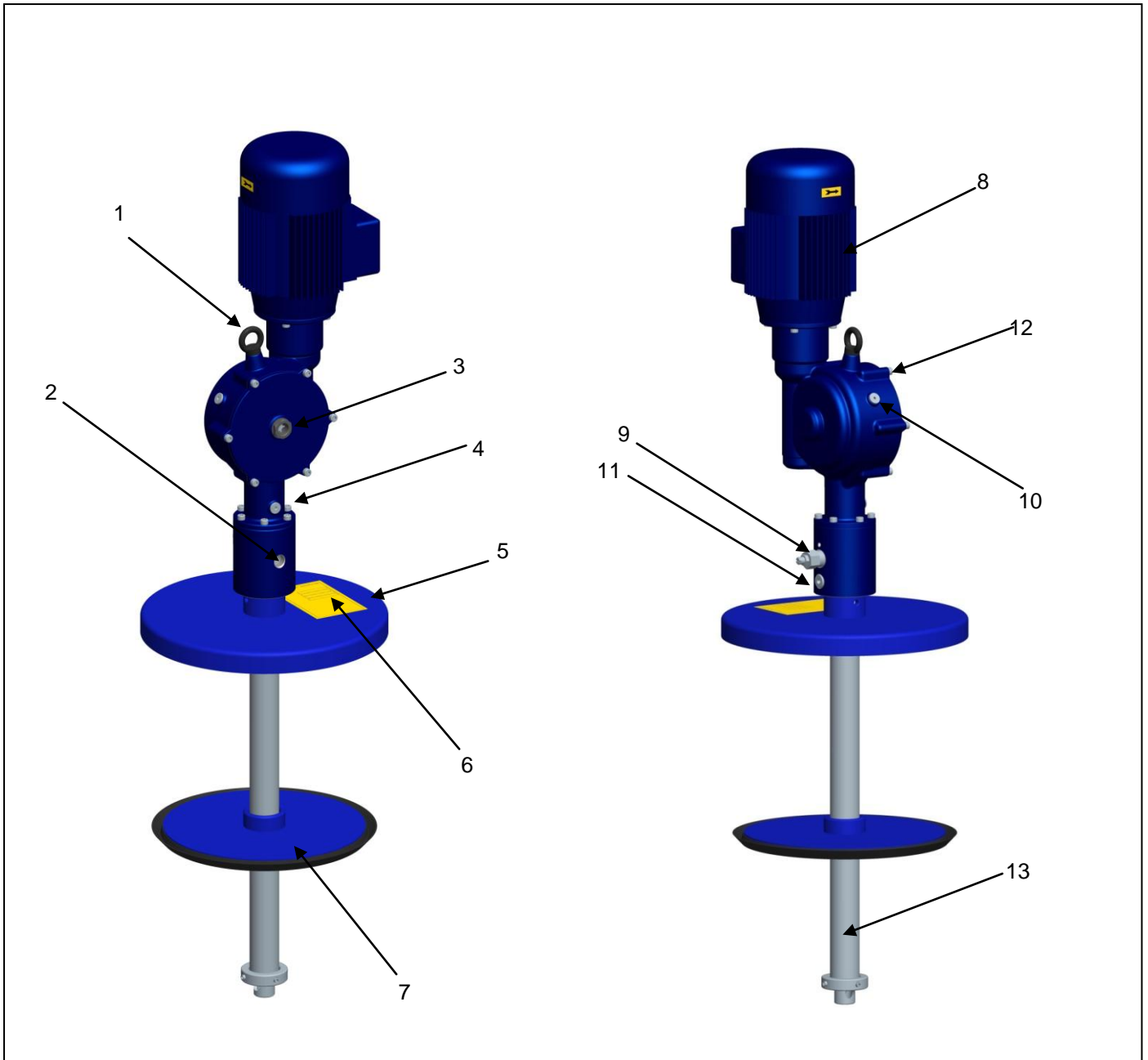

PUMP COMPONENTS	
1	Lifting Lug
2	Outlet
3	Oil lamp
4	Oil drain plug
5	Drum cover
6	Identification Label
7	Follower plate
8	Motor
9	By-pass
10	Oil Fill plug
11	Return Line (plugged)
12	Gearbox reducer
13	Pump Shaft

6. UNPACKING AND INSTALLATION

6.1 UNPACKING

Once a suitable installation position has been identified, unpack the pump and prepare for installation. It is important to inspect the pump to ensure that there has been no damage during transportation. The packaging material used does not require any special disposal procedures. You should refer to your regional requirements.

6.2 INSTALLATION

Allow sufficient space for the installation, leaving minimum 100 mm (3.93 in.) around the pump. Place the pump at shoulder height to avoid an unnatural posture or possibility of sustaining impacts.

CannonPumps must be installed vertically inserting the shank into the grease barrel until it reaches the bottom of the drum, using the lifting lug.

If you purchase separately the pump and the follower plate with lid, remove the ring on the pump shaft, put the lid and follower plate in the correct direction (the lip of the seal to the up) and finally put the ring in the initial position .

WARNING: When using a grease follower plate, it is recommended to check for crushes on drum sides which could prevent the follower plate from descending into the barrel. Use only intact drums with no defects.

6.3 ELECTRICAL CONNECTIONS

Damage to the power cable and terminal box could imply contact with parts power components and associated dangers of electricution. Care must be taken when making electrical connection.

- Check the integrity of the terminal box and the pump in general.
- In case of any damage, do not put the unit in operation
- If the power cable has been damaged, replace it immediately.
- Dismantling of the unit must be done by qualified maintenance personnel with electrical and mechanical skills..
- In order to prevent possibility of electricution due to earthing of live wires a differential trip should be fitted to the power supply to protect the user. Use a Trip device that activates at a differential level of 0,03 Ampere and a maximum of 1 second.



WARNING: Switching Isolation must equal 10 kA with a nominal current of 4 A

- The pump should never be used in hazardous environments or immersed in any fluids.
- Always use safety gloves and glasses when handling lubricants.
- Do not use lubricants that may contain substances incompatible with NBR Rubber.
- Follow all health and safety rules required by law.
- Attention: all electrical component must be earthed. This also includes all sensors. The earth cable should always be approximately 100mm longer than the signal wires and guarantee that if they become undone the earth cable is always the last one to disconnect

Check list before startup:

- Check integrity of the pump;
- Check Voltage and power supply is correct;
- Check lubricant is compatible;
- Ensure correct operating environment (temperature/humidity)
- Double Check all electrical connections.

7. INSTRUCTIONS FOR USE

1. Switch on the pump by pressing the start button on the control system in use;
2. Check that the pump is running;
3. Adjust the pressure by pass to the desired setting;
4. Verify that lubricant is correctly dispensed the lubrication system is functioning correctly (If there are any doubts on correct operation, to request test procedure please refer to Dropsa's Technical Department).

8. PROBLEMS AND SOLUTIONS



WARNING: The machine can be opened and repaired only by Dropsa authorized staff.

The following is a diagnostic table showing possible problems, causes and solutions.

Having consulted the following table, if problems still exist you should contact a specialized Dropsa technical support point for assistance in resolving any remaining problems.

N°	PROBLEM	POSSIBLE CAUSE	SOLUTIONS
01	The electric motor of the pump is not working	No power at the motor	Check the power supply system and the fuse.
02	The electric motor is working, but the pump does not deliver lubricant	Air trapped in the outlet or in the lubricant pumping chamber.	Disconnect the outlet tubing and cycle the pump until clean grease with no air bubbles is pumped from the outlet. Reconnect as appropriate.
03	The pump is working but no grease arrives at the lubrication point.	Broken Piping or leaking fitting.	Check the distribution system to ensure that no leaks are present and that the distribution system is functioning correctly.
04	The pump starts briefly but then stops.	Defective or overheated Motor.	Allow the motor to cool for a few minutes and then try again. If the problem persists the pump may need a service by a Dropsa technician.



CAUTION: Make sure the power supply, hydraulics are disconnected before performing any maintenance.

9. MAINTENANCE PROCEDURES

The pumps require only minimal maintenance.

To facilitate maintenance it is suggested to install the pump in an easily accessible location (see paragraph 6.2).

- Periodically check piping joints to detect possible leaks.
- Periodically check that there is sufficient oil in the gearbox. If necessary top up with ISO VG100 (DIN-51524-2) mineral gear oil.
- Keep the machine unit clear to readily detect possible leaks.

The machine does not require any special tool for checking or maintenance tasks. However, it is recommended the use only of appropriate and in good conditions tooling, protective devices (gloves) and clothing (in according to current regulations) to avoid hazards to equipment or persons.

10. DISPOSAL

The unit does not contain any harmful substances and should be disposed of following local regulations, including any recycling information indicated on the components themselves.

Upon demolition of the machine you must destroy the identification label and any other document.

11. ORDER INFORMATION

11.1 CANNONPUMP WITHOUT FOLLOWER PLATE AND COVER

Part Number	Drum Delivery (Kg)	Power supply
0234525	20-25	230/400Vac 3Ph – 50Hz – 0.55kW 240/415Vac 3Ph – 50Hz – 0.55kW 280/480Vac 3Ph – 60Hz – 0.65kW
0234535	50	
0234545	180/200	
0234526	20-25	110Vac 1Ph – 60 Hz – 0.9 kW
0234536	50	
0234546	180/200	
0234527	20-25	230Vac 1Ph – 50Hz – 0.55kW
0234537	50	
0234547	180/200	
0234528	20-25	24Vcc – 0.55kW
0234538	50	
0234548	180/200	

11.2 CANNONPUMP WITH FOLLOWER PLATE AND COVER

Part Number	Drum Delivery (Kg)	Power supply
0234520	20	230/400Vac 3Ph – 50Hz – 0.55kW 240/415Vac 3Ph – 50Hz – 0.55kW 280/480Vac 3Ph – 60Hz – 0.65kW
0234550	25	
0234530	50	
0234540	180/200	
0234521	20	110Vac 1Ph – 60 Hz – 0.9 kW
0234551	25	
0234531	50	
0234541	180/200	
0234522	20	230Vac 1Ph – 50Hz – 0.55kW
0234552	25	
0234532	50	
0234542	180/200	
0234523	20	24Vcc – 0.55kW
0234553	25	
0234533	50	
0234543	180/200	

11.3 SPARE PARTS AND ACCESSORIES

Pump Accessories and spare parts

Item	Pump size part number			
	20 Kg	25 kg	50 kg	180 / 200 kg
Cover	1141601	1141606	1141603	1141605
Follower Plate	1141600	1141607	1141602	1141604

Other spare parts

Part Number	Item
0234496	Bypass
3133456	200 kg Drum Lift Kit

Engines parts

Part Number	Power supply
3301536	230/400V AC 3Ph – 50Hz – 0.55kW
	240/415V AC 3Ph – 50Hz – 0.55kW
	280/480V AC 3Ph – 60Hz – 0.65kW
3301543	110V AC 1Ph – 60 Hz – 0.9 kW
3301542	230V AC 1Ph – 50Hz – 0.55kW
3301540	24V DC – 0.55kW

CANNONPUMP can be customized adding a minimum electric level or a laser probe, for other information contact Dropsa's Technical Office.

12. DIMENSIONS

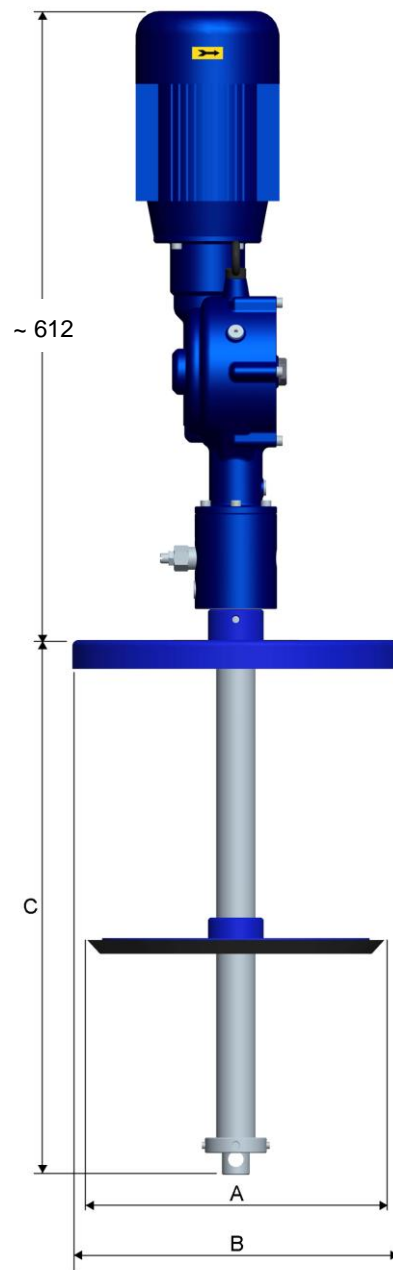

DRUM DELIVERY (kg)	A	B	C
20-25	290	315	520
50	365	400	720
180/200	590	600	900

13. HANDLING AND TRANSPORT

Prior to shipping, the equipment is carefully packed in cardboard package. During transportation and storage, always maintain the pump the right way up as indicated on the box. On receipt check that package has not been damaged. Then, storage the machine in a dry location.

Handling of the Pump must be done by at least two people.



Lift the packaging taking note of the orientation of the pump.

The product can withstand a storage temperature between -20 to + 50 °C; however it is necessary to ensure that the product has stabilized at a minimum temperature of +5 °C before putting it into operation

14. PRECAUTIONS FOR USE

It is necessary to read with due care all instructions regarding the use of this product.

The operator must know how to correct operate the product and all associated risks of having lubricants under pressure.

Therefore it is recommended:

- Verify chemical compatibility of the lubricant with the pump and the entire lubrication system. Ensure that all lubricant safety data is taken into consideration.
- Never exceed the maximum operating pressure or any characteristic of the pump. Check the product identification label.
- Only ever use original spare parts.
- Whenever a part is replaced anywhere in a lubrication system, ensure that it is rating and operating mode compatible with all other parts of the system.



WARNING!

Never attempt to stop or divert any leaks with hands or other body parts.

Note: It is important that all operators and maintenance personnel follow their local safety information. In particular always use personal protection equipment (gloves, safety glasses and protective clothing as a minimum) when handling this equipment or any lubricant. lubricants can often cause skin irritations and therefore appropriate safety measures must be adopted.



WARNING: It's necessary read carefully the warnings about the risks involving the use of a pump for lubricants. The user must know the operation through the User Manual and Maintenance.

Power supply

Any type of intervention must not be carried out before the unplugging of the machine from power supply.

Make sure that no one can start it up again during the intervention.

All the installed electric and electronic equipment, reservoirs and basic components must be grounded.

Flammability

The lubricant generally used in lubrication systems is not normally flammable.

However, it is advised to avoid contact with extremely hot substances or naked flames.

Pressure

Prior to any intervention, check the absence of residual pressure in any branch of the lubricant circuit as it may cause oil sprays when disassembling components or fittings.

After long periods of inactivity required to check all the pressure parts.

Do not subject to violent shocks of the fittings, pipes and parts under pressure.

A hose connection or a damaged are DANGEROUS, arrange for their replacement.

We recommend only the use of original spare parts.

Noise

During normal operating conditions the pump does not produce excessive noise (less than 70 dB(A)) at the distance of 1 m (39.3 inches) from the pump.



NOTE:

The pump has been designed to work with greases with a maximum viscosity of NLGI 2
Always use lubricants that are compatible with NBR Rubber.
The lubricant used during final testing of the unit is a NLGI 2 grease.

The following is a comparison table between NLGI (National Lubricating Grease Institute) and ASTM (American Society for Testing and Materials) for greases, showing the permissible values for the CannonPump

GREASES	
NLGI	ASTM
000	445 – 475
00	400 – 430
0	355 – 385
1	310 – 340
2	265 –295

For more information on technical and security measures, see the Security tab of the Product (Directive 93/112/EEC) relating to the type of lubricant chosen and supplied by the manufacturer.

15. OPERATIONAL HAZARDS

Verification and assessment relative to machine safety have been carried out according to the guidelines set out within the European Machine Directive using a matrix evaluation schematic with the generation of technical file as required by the directive.

The lists used are of two types:

- Risk evaluation (UNI EN ISO 14121-1).
- Conformity to essential safety requisites (Machine Directive –CE 06/42).

The following hazards have been identified as a result and must be considered during operation.

- During maintenance oil may be discharged at low pressures (oil squirt). To counter this, maintenance must be carried wearing appropriate personal protective clothing and glasses.
- Electricution: This can occur if the user does not securely connected the wires inside the terminal box. Electrical connections must therefore be carried out only by a competent electrician.
- Physical Strain due to poor positioning of the unit. Detailed Dimensional information is given in this manual to avoid poor positioning.
- Use of incorrect lubricant or fluids. Lubricant information is contained in this manual and on the pump itself.

FLUIDS NOT ALLOWED	
FLUIDS	DANGERS
Lubricants with abrasive additives	wear of pump internal components
Lubricants with silicone lubricant additives	Seizure of pumping element
Petrol - solvents - flammable liquid	Fire - explosion - damage to seals
Corrosive products	Corrosion of the pump - damage to people
Water	Oxidation of the pump
Food	Contamination

16. WARRANTY

All products manufactured and marketed by Dropsa are warranted to be free of defects in material or workmanship for a period of at least 12 months from date of delivery.

Extended warranty coverage applies as follows.

Complete system installation by Dropsa: 24 Months.

All other components: 12 months from date of installation; if installed 6 months or more after ship date, warranty shall be maximum of 18 months from ship date.

If a fault develops, notify Dropsa giving:

- ✓ A complete description of the alleged malfunction
- ✓ The part number(s)
- ✓ Test record number where available (format xxxxxx-xxxxxx)
- ✓ Date of delivery
- ✓ Date of installation
- ✓ Operating conditions of subject product(s)

We will subsequently review this information and supply you with either servicing data or shipping instruction and returned materials authorization (RMA) which will have instructions on how to prepare the product for return.

Upon prepaid receipt of subject product to an authorized Dropsa Sales & Service location, we will then either repair or replace such product(s), at our option, and if determined to be a warranted defect, we will perform such necessary product repairs or replace such product(s) at our expense.

Dropsa reserves the right to charge an administration fee if the product(s) returned are found to be not defective.

This limited warranty does not cover any products, damages or injuries resulting from misuse, neglect, normal expected wear, chemically caused corrosion, improper installation or operation contrary to factory recommendation.

Nor does it cover equipment that has been modified, tampered with or altered without authorization.

Consumables and perishable products are excluded from this or any other warranty.

No other extended liabilities are stated or implied and this warranty in no event covers incidental or consequential damages, injuries or costs resulting from any such defective product(s).

The use of Dropsa product(s) implies the acceptance of our warranty conditions. Modifications to our standard warranty must be in writing and approved by Dropsa.

17. DECLARATION OF COMPLIANCE

Dropsa

Dropsa Spa
Via Benedetto Croce, 1
20090 Vimodrone (MI)
Italy

Tel.: (+39) 02. 250.79.1
Fax Sales: (+39) 02. 250.79.767
E-mail: sales@dropsa.it
Web site: <http://www.dropsa.com>



DICHIARAZIONE **CE** DI CONFORMITÀ/DECLARATION OF COMPLIANCE WITH STANDARDS/ DECLARATION DE CONFORMITE/ KONFORMITÄTSEKTLÄRUNG DES STANDARDS /DECLARACIÓN DE CONFORMIDAD/ DECLARAÇÃO DE CONFORMIDADE

La società Dropsa S.p.A., con sede legale in Milano, Via Besana,5/ Dropsa S.p.A., registered office in Milan, Via Besana,5 / Dropsa S.p.A. au Siège Social à Milan, Via Besana,5/ Dropsa S.p.A., Sitz in Milano, Via Besana 5/ La sociedad Dropsa S.p.a., con sede legal en Milán, Via Besana,5/ A Dropsa S.p.A, com sede em Milão, via Besana, nº 5

DICHIARA /CERTIFIES / CERTIFIE/ ZERTIFIZIERT, DASS/ DECLARA/ CERTIFICA:

che il prodotto denominato/that the product called/ le produit appellé/ das Produkt mit dem Namen/ el producto que se llama/ o produto chamado:

Descrizione/ Description/ Description/ Beschreibung/ Descripción/ Descrição:	Pompa per fusti / Barrel Pump
Nome Commerciale/ Product Name/ Dénomination/ Handelsname/ Denominación/ Denominação:	CANNONPUMP
Versioni/ Versions/ Versions/ Versionen/ Versiones/ Versões:	Tutte
Codici/ Codes/ Códigos/:	Serie 02345**

è conforme alle condizioni previste dalle Direttive CEE /has been constructed in conformity with the Directives Of The Council Of The European Community on the standardization of the legislations of member states/ a été construite en conformité avec les Directives Du Conseil Des Communautés Europeennes/ Entsprechend den Richtlinien des Rates Der Europäischen Union, für die Standardisierung der Legislative der Mitgliederstaaten, konstruiert wurde/ cumple con las condiciones establecidas por las directivas comunitarias/ foi construído em conformidade com as diretivas do Conselho das Comunidades Europeias:

- 2006/42 CE Direttiva macchine /Machinery Directive/ Directive machines/ Maschinenrichtlinien/Maquinaria / Directiva Máquinas;
- 2006/95 CE Bassa tensione / Low Voltage Directive / Directive Basse Tension/ Niederspannungsrichtlinien/ Directiva de baja tensión/ Directiva de Baixa Tensão;

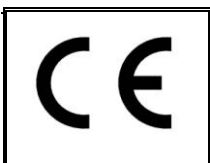

La persona autorizzata a costituire il Fascicolo Tecnico presso Dropsa S.P.A.
The person authorized to compile the Technical File care of Dropsa S.P.A.

Technical Director:
Maurizio Greco

[Signature]

Legal representative
Mileva Gavazzi

[Signature]

Vimodrone (MI), Novembre 2011

Copy of the original document

18. DISTRIBUTORS

 **Dropsa S.p.A.**
Via B. Croce,1
20090 Vimodrone (MI) Italy.
Tel: (+39) 02 - 250.79.1
Fax: (+39) 02 - 250.79.767
E-mail: sales@dropsa.it (Export)
E-mail: vendite@dropsa.it (National)

 **Dropsa (UK) Ltd**
Unit 6, Egham Business Village,
Egham, Surrey, TW20 8RB
Tel: (+44) 01784 - 431177
Fax: (+44) 01784 - 438598
E-mail: salesuk@dropsa.com

 **Dropsa USA Inc.**
6645 Burroughs Ave
48314-2132 Srerling Hts, Mi Us -USA
Tel: (+1) 586-566-1540
Fax: (+1) 586-566-1541
E-mail: salesusa@dropsa.com

 **Dropsa GmbH**
Volmerswerther Strasse 80
40221 Dusseldorf 1, Deutschland
Tel: (+49) 0211/39 4011
Fax: (+49) 0211/39 4013
E-mail: sales@dropsa.de

 **Dropsa Ame**
23, Av.des.Morillons
Z.I. des Doucettes 91140
Garges Les Gonesse, France
Tel: (+33) 01 39 93 00 33
Fax: (+33) 01 39 86 26 36
E-mail: salesfr@dropsa.com

 **Dropsa do Brazil Ind. E Com. Ltda**
Rua Sobralia 175,
Sao Paulo, Brazil
Tel: (+55) 011-5631-0007
Fax: (+55) 011-5631-9408
E-mail: salesbr@dropsa.com

 **Dropsa Lubrication Systems**
Nr 8 Dongxing Road,
Songjiang Industrial Zone
(Shanghai) Co., Ltd
Tel: +86 (021) 67740275
Fax: +86 (021) 67740205
E-mail: china@dropsa.com

 **Dropsa Australia Pty.**
C20/148 Old Pittwater Road
Brookvale, NSW 2100
Tel: +61 (02) 9938 6644
Fax: +61 (02) 99 386 611
E-mail: salesau@dropsa.com



Web site: <http://www.dropsa.com> - E-mail: sales@dropsa.com